

## EF TAPPING SADDLE

04 Update - 05/2024

### TECHNICAL DATA

Article No	001 117 2071 0093
d (mm)	90
d1 (mm)	50
le (mm)	92
h (mm)	195
h1 (mm)	65
Z (mm)	148
L (mm)	140
Weight (Kg)	0,760
Box Quantity (pcs)	12
Box Dimension (cm)	55x30x37,5

### INJECTION MOULDED

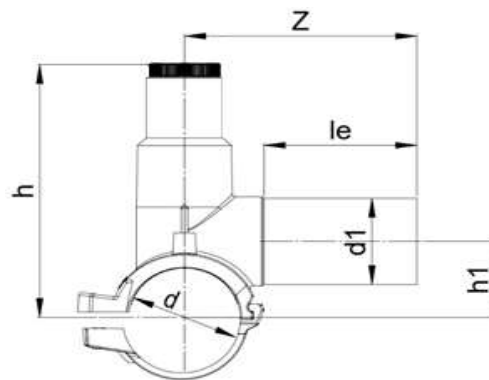

### IDENTIFICATION OF PRODUCT

D(mm)	90-50
SDR	11
RAW MATERIAL	PE 100
PRESSURE CLASS	16 Bar Water 10 Bar Gas
TRADEMARK	NTG
EXECUTION	Injection Moulded
STANDARD	EN 12201-3 EN 1555-3 AS / NZS 4129

SPECIFICATION	Suitable for SDR11....17 pipe Injected monobloc type 4 mm pin connectors Long Fusion outlet Hexagon wrench 17 mm O-ring sealed screw cap
---------------	---

### EF SPECIFICATION

WELDING VOLTAGE	40 V
RESISTANCE	7,0 Ω
WELDING TIME	140 Sec.
COOLING TIME	15 Min.
WINDING TYPE	Monofilar

### WELDING BARCODE



Tolerance on diameters and thickness according to the standards. The other dimensions are specialized. Tolerance  $\pm 5\%$ . NTG PLASTIK reserves all the right to change any information without giving prior notice. The production, distribution and utilization of this document without explicit authorization is prohibited.